

Stage insert not shown

## Scanning Stage SCAN 75 × 30 for Meiji MT 4000–8500

### Specifications

Travel range	max. 75 × 38 mm
Travel speed	max. 25 mm/s (with 1 mm ball screw pitch) max. 50 mm/s (with 2 mm ball screw pitch)
Repeatability	< 1 µm (bi-directional) <sup>1</sup>
Accuracy	±3 µm <sup>1</sup>
Resolution	0.01 µm (smallest step size)
Orthogonality	< 10 arcsec
Motor	2-phase stepper motor
Limit switches	optical light beams
Stage opening	116 × 116 mm
Material / surface	aluminium / anodic coating, black laquered
Weight	approx. 2.6 kg (without stage insert)

### Order Information

Order No.: 96-24-561-0000 (1 mm)  
Order No.: 96-24-562-0000 (2 mm)

### Product Features

- ▶ flat, ergonomic design with rounded corners
- ▶ plain surface for easy cleaning
- ▶ exchangeable stage inserts for different kinds of applications
- ▶ motor cable connection front right
- ▶ integrated electronic stage identification device ETS for automatic identification of the scanning stage and parametrization of the controller
- ▶ **5 years guarantee**, if the scanning stage is operated in the system with the Märzhäuser TANGO controller

### Dimensions

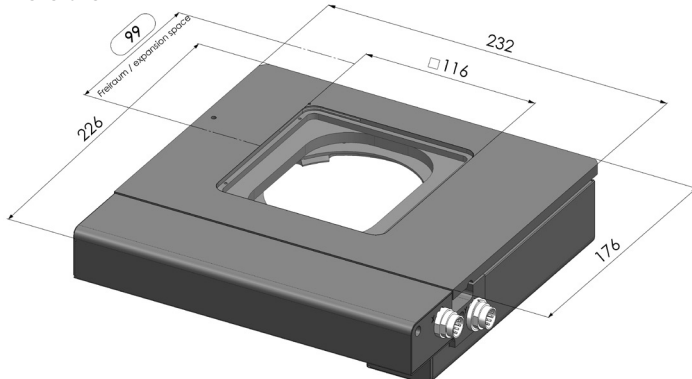

### Accessories

Stage insert for 1 slide 76 × 26 mm  
(3" × 1", included in delivery)  
Order No.: 96-29-401-8010

Stage insert for 1 metal slide 76 × 26 mm  
Order No.: 96-29-401-8020

For further accessories please visit:  
[www.marzhauser.com](http://www.marzhauser.com)